



1. Product Name

Hug 'n' Hold

2. Product Code

22950

3. Colour

Green as standard (red or blue by special request)

4. Brief Description

Designed to provide vestibular input, encourage good balance and improve weight-shifting abilities and co-ordination.

5. Contents

- 1 x fully assembled Hug 'n' Hold with a Safety Snap

6. Snoezelen® Stimulations

- *Not applicable*

7. Best Use

Use with an appropriate frame or suspension system.

8. Compatible ROMPA® Products

21559 Safety Rotational Device

22948, 22947 A Frame

22619, 22618 C Frame

20782, 22620 O Frame

21928 Hanging Bracket

17687 Suspension System

Consider products and activities that complement Sensory Integration therapy such as Projectors, Bean Bags, Balls etc.

Contact ROMPA® for wall and floor mats – we can manufacture these to your required size, depth and density.

9. Starting Up

- Suspend the swing from one appropriate suspension point.

10. Detailed Description

Designed to provide vestibular input, encourage good balance and improve weight-shifting abilities and co-ordination. Maximum weight supported: 136kg.

11. Safety

- Always supervise the use of this product
- This product is not a toy.
- Do not exceed the maximum working load of 136kg (300 lbs).
- The client should always wear a safety helmet with all suspended equipment.
- Use mats of an appropriate thickness under and all around the suspended equipment.

12. Technical Specification

Size: 118L x 29W x 100cmH (base 18cmH)

Vinyl

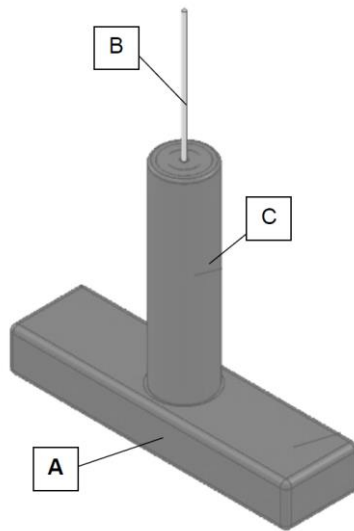

- A. Padded bolster
- B. Support rope
- C. Padded vertical

13. Installation

1. For indoor use only. Suspend from an appropriate suspension frame or bracket. The Hug 'n' Hold should be hung from one suspension point.
2. Install (and store) away from sources of naked flames, cigarettes and sources of heat including open fireplaces, radiators and heaters.
3. A minimum ceiling height of 2.4m (8') is recommended.
4. The use of a Safety Rotational Device is recommended (to be purchased separately) to prevent abnormal wear.
5. This product has been designed for use with A, O and C Frames. If this swing is being used with a different frame or suspension point, ensure that the swing is attached via a forged steel eyebolt (1/2" or 5/8").

14. Care and Maintenance

1. Regularly check the product for signs of wear and tear. If any part is loose, damaged or functioning incorrectly, cease use until the problem is rectified. Keep a record of dates of inspection and of any issues found (a service and inspection record form is included with the product from the manufacturer).
2. Keep the product clean using a damp cloth and a mild detergent. Stubborn marks should be cleaned using a soft brush. Do not soak or immerse the product in water. Do not use bleach, solvents, abrasives, synthetic detergents, wax polishes, antibacterial sprays or antibacterial wipes.
3. Store in a cool and dry place that is out of direct sunlight and out of reach of clients to avoid unsupervised use.
4. It is recommended that the product is serviced every three years. If the product has been out of use for six months or more, it is recommended that the product is serviced prior to re-use. If the product has been subjected to 'heavy' or 'constant' use, the service should occur in half the above recommended time. 'Constant' / 'heavy' use is considered to be:
 - Daily use above 7 hours duration
 - Weekly use above 5 days duration
 - Monthly use above 10 months per year
 - Use by a client who is at 90% to 100% of the maximum weight limit
 - Use by a client who is extremely active, either voluntarily or involuntarilyContact ROMPA® for advice.
5. This product has a nominal service life of 12 years, based on anticipated exposure to normal use.
6. Do not attach any other products to this swing (other than safety snaps and rotational safety devices). Do not alter the swing.

15. Troubleshooting

Not applicable

Further copies of these instructions can be downloaded at www.rompa.com

We hope you find our instructions invaluable. If you have any suggestions for improving them further your comments will be greatly received – please contact us at producthelp@rompa.com